

Automatic Door Sensors



ADS-A Series CATALOG

For your safety, read and follow the considerations written in the instruction manual, other manuals and Autonics website.

The specifications, dimensions, etc. are subject to change without notice for product improvement. Some models may be discontinued without notice.

Features

- Adjustable hold time switch (2, 7, 15 sec)
- 4-step detection angle adjustment (7.5°, 14.5°, 21.5°, 28.5°)
- Adjustable sensing area (left / right area elimination)
- Power supply
 - : 24-240 VAC~ / 24-240 VDC== (universal AC / DC type),
 - 12-24 VAC~ / 12-24 VDC== (universal AC / DC type)
- Built-in microprocessor
- Max. sensing area : 2460 × 86 mm (installation height 2.7 m)

Ordering Information

This is only for reference, the actual product does not support all combinations. For selecting the specified model, follow the Autonics website.

ADS - A ①

① Power supply

F: 24-240 VAC~ / VDC==

E: 12-24 VAC~ / VDC==

Product Components

- Product × 1
- Instruction manual × 1
- Mounting connector cable (2.5 m) × 1
- Mounting screw × 2
- Mounting template × 1

Specifications

Model	ADS-A□
Mounting height	2.0 to 2.7 mm ⁰¹⁾
Sensing area	9-point
Sensing method	Infrared reflection method
Output holding time	Time delay ≈ 0.5 sec
Stationary sensing time	2 sec, 7 sec, 15 sec (holding time setting switch)
Interference prevention	H, L (interference prevention switch)
Adjust angle	7.5°, 14.5°, 21.5°, 28.5° (angle adjustment lever)
Eliminate right / left sensing area	(1, 2, 3 area), (7, 8, 9 area) (eliminating right / left sensing area lever)
Light source	Infrared chip diode (modulated)
Indicator	Operation indicator (orange, green, red)
Approval	ERC
Weight	≈ 320 g

01) In case of installing the unit higher than 2.7 m height, the unit may not detect small children. In case of installing the unit lower than 2.0 m height the unit may not work normally.

Power supply	ADS-AF: 24 - 240 VAC~, 50 / 60 Hz, 24 - 240 VDC== (ripple P-P: ≤ 10%) ADS-AE: 12 - 24 VAC~, 50 / 60 Hz, 12 - 24 VDC== (ripple P-P: ≤ 10%)
Power consumption	ADS-AF: ≤ 4 VA (≤ 240 VAC~ at 50 / 60 Hz) ADS-AE: ≤ 2 VA (≤ 24 VAC~ at 50 / 60 Hz)
Control output	Relay contact output
Relay contact capacity ⁰¹⁾	50 VDC== 0.1 A (resistive load)
Relay contact composition	1a
Relay life cycle	Mechanical: ≥ 20,000,000 times, electrical: ≥ 50,000 times
Insulation resistance	≥ 20 MΩ (500 VDC== megger)
Noise immunity	± 2,000 VDC== the square wave noise (pulse width: 1 μs) by the noise simulator
Dielectric strength	1,000 VAC~ 50 / 60 Hz for 1 minute
Vibration	1.5 mm double amplitude at frequency of 10 to 55 Hz (for 1 minute) in each X, Y, Z direction for 2 hours
Shock	100 m/s ² (≈ 10 G) in each X, Y, Z direction for 3 times
Ambient illumination (receiver)	Sunlight: ≤ 3,000 lx, incandescent lamp: ≤ 3,000 lx
Ambient temperature	-20 to 50 °C, storage: -20 to 70 °C (no freezing or condensation)
Ambient humidity	35 to 85 %RH, storage: 35 to 85 %RH (no freezing or condensation)
Protection	IP50 (IEC standard)
Connection	Cable connector type
Material	Case: ABS, lens: acryl, lens cover: acryl

01) Do not use the load which is beyond the rated capacity of contact point of relay. It may cause bad insulation, contact fusion, bad contact, relay breakdown, and fire etc.

Dimensions

- Unit: mm, For the detailed drawings, follow the Autonics website.

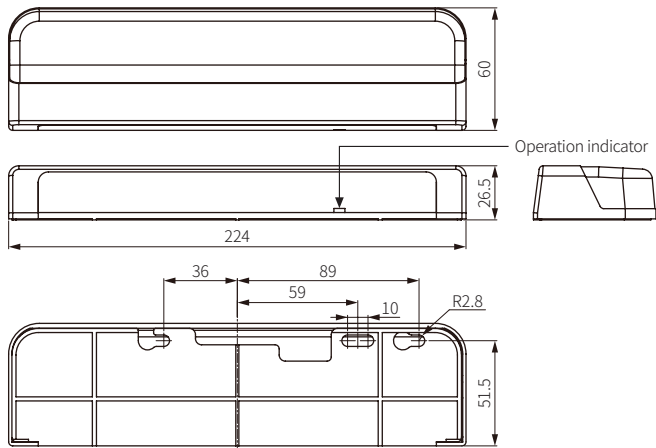

Unit Descriptions

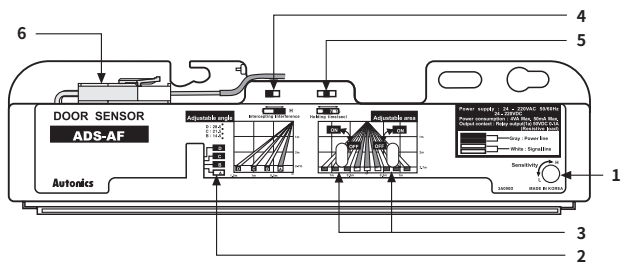

1	Sensitivity adjustment switch	2	Angle adjustment lever	3	Eliminating right/left sensing area lever
4	Interference prevention switch	5	Holding time setting switch	6	Body connector